



Ordering Procedure

1

Select complete Accessory from Table 1

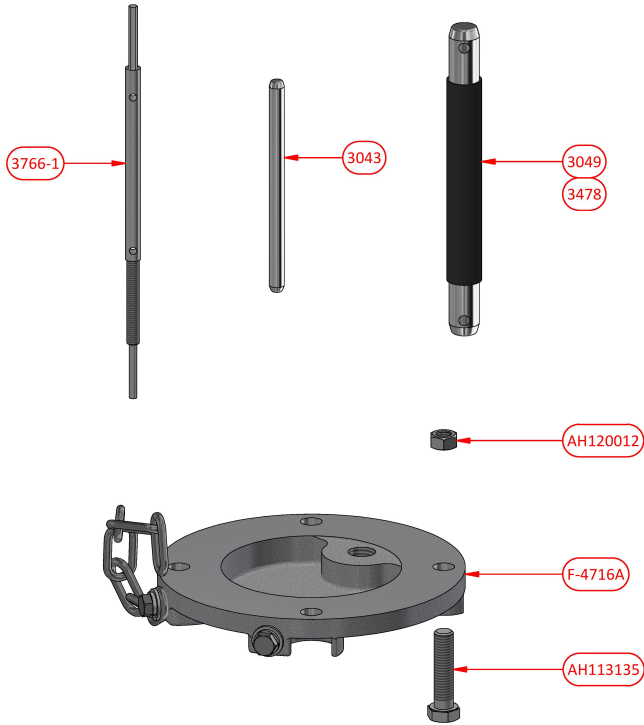

Table 1

Part Number	Description
F-4716A	300/425A Blanking Cover
	300A Phase Pin
3478	425A Phase Connecting Pin
	Pilot Pin
3766-1	Socket Extraction Tool
AH113135	Screw M12 x 50 hex. head
AH120012	Nut M12

Compliance

Non Hazardous Area Only. Dimensions to AS/NZS1300  
 Aluminium / Silver Plated Copper

Materials

**CMi Head Office NSW** | (02) 9807 6155 | F3, 3-29 Birnie Ave, Lidcombe, NSW, 2141 | [nswsales@cmielectrical.com.au](mailto:nswsales@cmielectrical.com.au)  
**CMi QLD-Brisbane**  
 (07) 3863 0749  
 485A Zillmere Road,  
 Zillmere QLD 4034  
[southqdsales@cmielectrical.com.au](mailto:southqdsales@cmielectrical.com.au)

**CMi QLD - Rockhampton**  
 (07) 4921 0978  
 Shop 3 at 76 Hollingsworth Street,  
 North Rockhampton Qld 4701  
[northqdsales@cmielectrical.com.au](mailto:northqdsales@cmielectrical.com.au)

**CMi VIC**  
 (03) 9532 1233  
 3 Dissik Street,  
 Cheltenham VIC 3192  
[vicsales@cmielectrical.com.au](mailto:vicsales@cmielectrical.com.au)

**CMi WA**  
 (08) 9358 1788  
 36 Division Street,  
 Welshpool WA 6106  
[wasaales@cmielectrical.com.au](mailto:wasaales@cmielectrical.com.au)