

Bolted Adaptor
B374A - B474A

300/425 Amp Series C (Aluminium)

Body Size C - 6600V

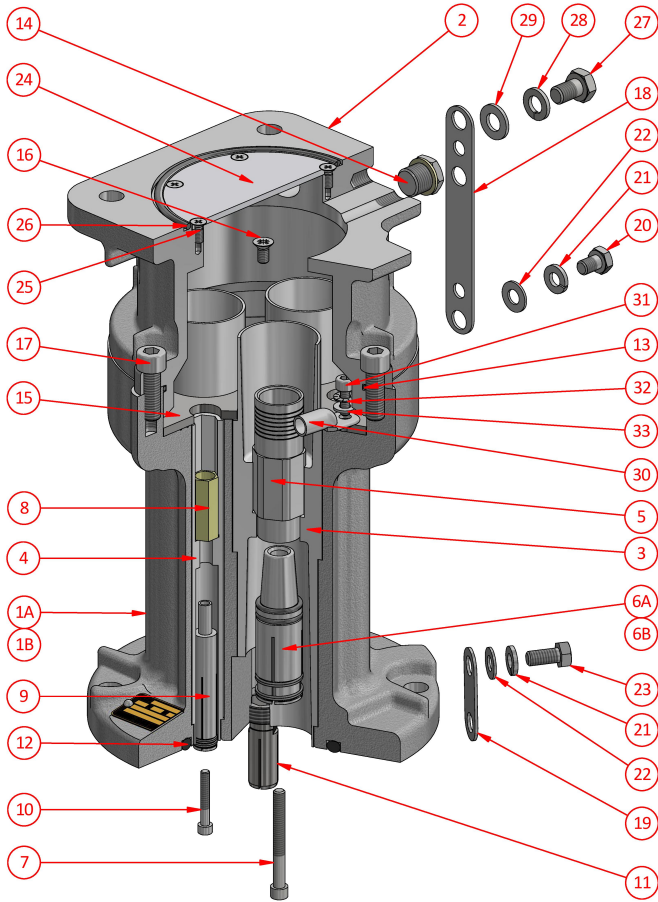

Weight 10kg
Dimensions L 220mm W 220mm H 330mm
Compliance Non Hazardous Area Only. Dimensions to AS/NZS 1300
Materials Aluminium / PTFE
IP Rating IP66

Ordering Procedure

- 1 Select complete Adaptor from Table 1
- 2 Select Phase Thimble from Table 2 (3 Required)
- 3 Select Accessories from Aluminium Body Size C Accessories

Table 1

Part Number	Description	Colour
B374A	300A 6600V Bolted Adaptor	Silver
B474A	425A 6600V Bolted Adaptor	Silver

NB. Adaptor supplied with Pilot Thimble

Table 2

Phase Thimble - screw AH009868 3/16" x 1 1/4" skt. head

Part Number	CSA	ID mm	Utilux Die No.
F-201-432	25	8.0	38-92 Cu
F-201-302	35	9.5	38-115 Cu
F-201-303	50	10.5	38-115 Cu
F-201-303-1	70	12.8	38-142 Cu
F-201-304-1	95	14.0	38-165 Cu
F-201-305-1	120	16.0	38-165 Cu
F-201-306-1	150	18.0	38-183 Cu
F-201-307-1	185	21.8	SOLDER ONLY
F-201-326-1	240	24.2	SOLDER ONLY
F-3641	300	26.3	40-281 Cu
F-3641-1	240	24.2	40-281 Cu
F-3641-2	185	21.2	38-231 Cu

NB: CSA is indicative only. Use ID for thimble selection

Spare Parts

#	Part Number	Description
1A	F-4707A-374	300A 6600V Coupler Body c/w items 1A, 11, 12, 15, 16, 18, 19, 20, 21, 22 & 23
1B	F-4707A-474	425A 6600V Coupler Body c/w items 1B, 11, 12, 15, 16, 18, 19, 20, 21, 22 & 23
2	F-4706A	6600V Adaptor Box Assembly
3	MO4700	Phase Pin Insulator
4	MO4701	Pilot Socket Insulator
5	See Table 2	Phase Thimble
6A	F-201-299	300A Phase Socket c/w O-ring AI019013
6B	F-201-300-1	425A Phase Socket c/w O-ring AI019013
7	AH009868	Screw 1/4" x 2 1/4" skt. head
8	F-3727	Pilot Thimble c/w screw AH009834 3/16" x 1 1/4" skt. head
9	F-3042-1	Pilot Socket
10	AH009834	Screw 3/16" x 1 1/4" skt. head
11	4708	Earth Connector
12	AI018993	O-ring ID 113.67 x sect. 6.99
13	AI019057	O-ring ID 145.72 x sect. 2.62
14	F-PM16SS	M16 Blanking Plug c/w Sealing Washer
15	4699	Retaining Plate
16	AH151037	Screw M6 x 12 csk. head
17	AH115114	Screw M10 x 30 skt. head
18	201-264-1	Earth Strap
19		Earth Strap
20	AH113091	Screw M8 x 10 hex. head
21	AH151071	Spring Washer M8
22	AH009277	Washer 5/16"
23	AH113097	Screw M8 x 16 hex. head
24	3066-1	Cable Spreader Plate
25	AH151034	Screw M5 x 12 csk. head
26	AI019045	O-ring ID 110.72 x sect. 3.53
27	AH113111	Screw M10 x 16 hex. head
28	AH151011	Spring Washer M10
29	AH150011	Washer M10
30	CCAL35-6	Earth Lug
31	AH115112	Screw M6 x 16 skt. head
32	AH152001	Serrated Washer M6
33	AH009273	Washer 1/4"