



Back to Back Receptacle  
 AH214S

125 Amp Series

1100V

Ordering Procedure

- 1 Select complete Back to Back from Table 1

Table 1



Part Number	Description	Colour
AH214S	1100V Restrained Back to Back Receptacle	Blue

Spare Parts

#	Part Number	Description
1	F-4691S-214	1100V Back to Back Body c/w items 1 & 3
2	F-852	Interior c/w screws AH112500 M5 x 20 csk. head
3	F-851	Jacking Screw
4	F-310	Sealing Plug

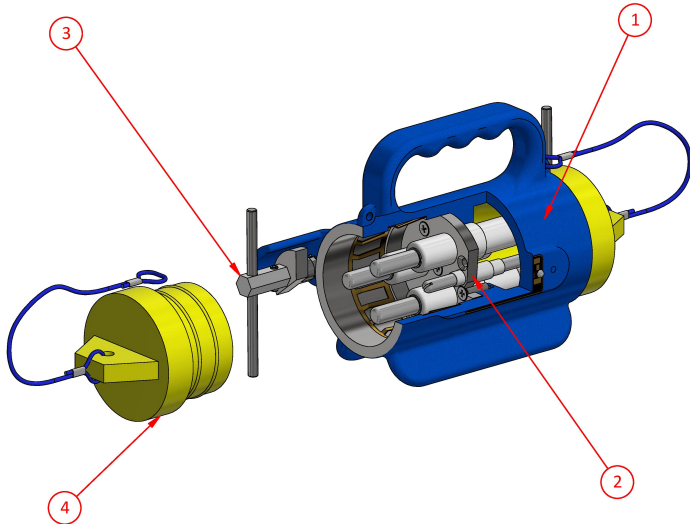

**Weight** 7kg  
**Dimensions** L 170mm W 210mm H 310mm  
**Compliance** Explosion protected to AS/NZS1299 & IEC60079 Series  
**Materials** Stainless Steel / PTFE  
**IP Rating** IP66

**CMI Head Office NSW** | (02) 9807 6155 | F3, 3-29 Birnie Ave, Lidcombe, NSW, 2141 | nswsales@cmielectrical.com.au  
**CMI QLD-Brisbane**  
 (07) 3863 0749  
 485A Zillmere Road,  
 Zillmere QLD 4034  
 southqdsales@cmielectrical.com.au

**CMI QLD - Rockhampton**  
 (07) 4921 0978  
 Shop 3 at 76 Hollingsworth Street,  
 North Rockhampton Qld 4701  
 northqdsales@cmielectrical.com.au

**CMI VIC**  
 (03) 9532 1233  
 3 Dissik Street,  
 Cheltenham VIC 3192  
 vicsales@cmielectrical.com.au

**CMI WA**  
 (08) 9358 1788  
 36 Division Street,  
 Welshpool WA 6106  
 wasales@cmielectrical.com.au