

Phase Condition Indicator Plug  
AM431SLA  
AT434S - AT434SS

425 Amp Series

3300V

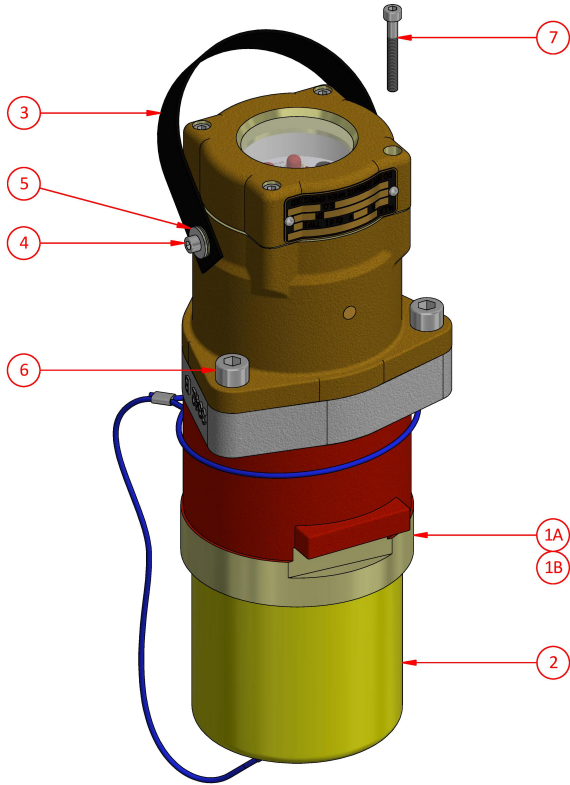

Ordering Procedure

1

Select complete Phase Indicator Plug from Table 1

Table 1



Part Number	Description	Colour
AM431SLA	3300V Phase Condition Indicator Plug RTX	Red/Silver
AT434S	3300V Phase Condition Indicator Plug	Red/Silver
AT434SS	3300V Phase Condition Indicator Plug (Stainless steel nose cone)	Red/Silver

Spare Parts

#	Part Number	Description
1A	F-3342-434	3300V Nose Cone c/w O-ring AI019023
1B	F-3342-434SS	3300V Nose Cone Stainless Steel c/w O-ring AI019023
2	F-264L	Protection Cap
3	F-AX000400	Handle
4	AH151033	Screw M5 x 16 skt. head
5	AH009251	Washer 3/16"
6	AH117113	Screw M10 x 40 skt. head
7	AH151015	Screw M5 x 40 skt. head

**Weight** 10kg  
**Dimensions** L 150mm W 150mm H 410mm  
**Compliance** Explosion protected to AS/NZS1299 & IEC60079 Series  
**Materials** Manganese Bronze / Polyester / Stainless Steel  
**IP Rating** IP66

**CMI Head Office NSW** | (02) 9807 6155 | F3, 3-29 Birnie Ave, Lidcombe, NSW, 2141 | nswsales@cmielectrical.com.au  
**CMI QLD-Brisbane**  
 (07) 3863 0749  
 485A Zillmere Road,  
 Zillmere QLD 4034  
 southqdsales@cmielectrical.com.au  
**CMI QLD - Rockhampton**  
 (07) 4921 0978  
 Shop 3 at 76 Hollingsworth Street,  
 North Rockhampton Qld 4701  
 northqdsales@cmielectrical.com.au

**CMI VIC**  
 (03) 9532 1233  
 3 Dissik Street,  
 Cheltenham VIC 3192  
 vicsales@cmielectrical.com.au

**CMI WA**  
 (08) 9358 1788  
 36 Division Street,  
 Welshpool WA 6106  
 wasales@cmielectrical.com.au