

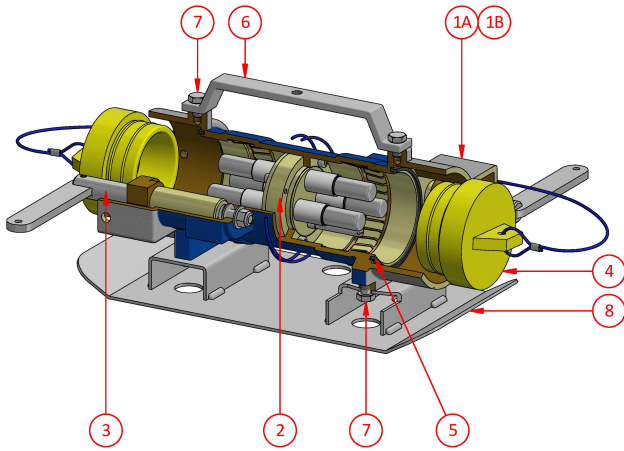

Back to Back Receptacle
 AH464B - AH414B
 AH464BS - AH414BS

425 Amp Series
 660V - 1100V



Weight 18kg (no skid) 20kg (with skid)
Dimensions L 430mm W 280mm H280mm
Compliance Explosion protected to AS/NZS1299 & IEC60079 Series
Materials Manganese Bronze / Brass / PTFE
IP Rating IP66/68

CMi Head Office NSW | (02) 9807 6155 | F3, 3-29 Birnie Ave, Lidcombe, NSW, 2141 | nswsales@cmielectrical.com.au
CMi QLD-Brisbane
 (07) 3863 0749
 485A Zillmere Road,
 Zillmere QLD 4034
southqldsales@cmielectrical.com.au
CMi QLD - Rockhampton
 (07) 4921 0978
 Shop 3 at 76 Hollingsworth Street,
 North Rockhampton Qld 4701
northqldsales@cmielectrical.com.au

Ordering Procedure

- 1 Select Complete Back to Back from Table 1

Table 1

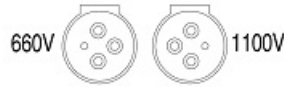

Part Number	Description	Colour
AH464B	660V Back to Back Quick Release Receptacle	Orange/Silver
AH414B	1100V Back to Back Receptacle	Blue / Silver
AH464BS	660V Back to Back Receptacle c/w skid	Orange/Silver
AH414BS	1100V Back to Back Receptacle c/w skid	Blue/Silver

Spare Parts

#	Part Number	Description
1A	F-4105-464	660V Back to Back Body c/w items 1A, 3, 5, 6 & 7
1B	F-4105-414	1100V Back to Back Body c/w items 1B, 3, 5, 6 & 7
2	F-4585-2	Interior c/w screws AH115112 M6 x 16 skt. head
3	F-329	Jacking Screw
4	F-311	Sealing Plug
5	4401-3	Seal
6	4035	Lifting Handle
7	AH113111	Screw M10 x 16 hex. head
8	4043S	Skid Plate

CMi VIC
 (03) 9532 1233
 3 Dissik Street,
 Cheltenham VIC 3192
vic-sales@cmielectrical.com.au

CMi WA
 (08) 9358 1788
 36 Division Street,
 Welshpool WA 6106
wasa-sales@cmielectrical.com.au