



TRS Cable Gland  
 F-3222T

No.2 to No.5 Glands

To suit Series B, C & D Couplers

Ordering Procedure

- 1 Select complete Gland from Table 1
- 2 Select Grommet from Table 2

Table 1

Part Number	Description
F-3222T	No.5 TRS Cable Gland to suit 65.0-101.0mm O.D. Cable

Table 2

Silicone Grommets	
Part Number	Cable Acceptance mm
4666-73S	65.0-73.0
4666-80S	72.0-80.0
4666-87S	79.0-87.0
4666-94S	86.0-94.0
4666-101S	93.0-101.0

Spare Parts

#	Part Number	Description
1	3225B	Clamping Cap
2	See Table 2	Silicone Grommet
3	AH113154	Screw M16 x 60 hex. head
4	AH113134	Screw M12 x 35 hex. head
5	AI019010	O-ring ID 120.24 x sect. 3.53
6	AH017206	Earth Lug
7	AH115115	Screw M6 x 10 button head
8	201-264-1	Earth Strap
9	AH113111	Screw M10 x 16 hex. head
10	AH151011	Spring Washer M10
11	AH150011	Washer M10

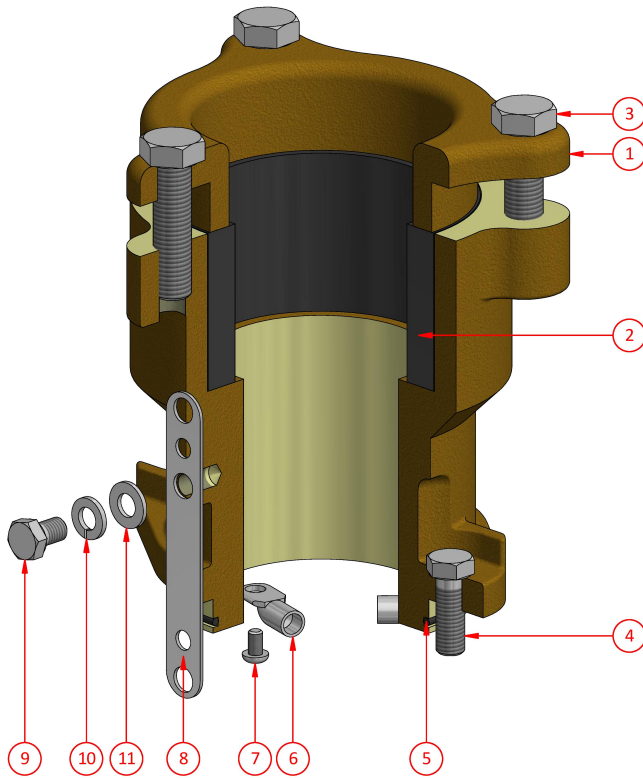

Weight 15kg  
 Dimensions L 200mm W 210mm H 280mm  
 Compliance Explosion protected to IEC60079 Series  
 Materials Manganese Bronze  
 IP Rating IP66/68

**CMI Head Office NSW** | (02) 9807 6155 | F3, 3-29 Birnie Ave, Lidcombe, NSW, 2141 | [nswsales@cmielectrical.com.au](mailto:nswsales@cmielectrical.com.au)  
**CMI QLD-Brisbane**  
 (07) 3863 0749  
 485A Zillmere Road,  
 Zillmere QLD 4034  
[southqldsales@cmielectrical.com.au](mailto:southqldsales@cmielectrical.com.au)

**CMI QLD - Rockhampton**  
 (07) 4921 0978  
 Shop 3 at 76 Hollingsworth Street,  
 North Rockhampton Qld 4701  
[northqldsales@cmielectrical.com.au](mailto:northqldsales@cmielectrical.com.au)

**CMI VIC**  
 (03) 9532 1233  
 3 Dissik Street,  
 Cheltenham VIC 3192  
[vic-sales@cmielectrical.com.au](mailto:vic-sales@cmielectrical.com.au)

**CMI WA**  
 (08) 9358 1788  
 36 Division Street,  
 Welshpool WA 6106  
[wasa-sales@cmielectrical.com.au](mailto:wasa-sales@cmielectrical.com.au)