

Back to Back Receptacle
 AH334B - AH334BS

300 Amp Series

3300V

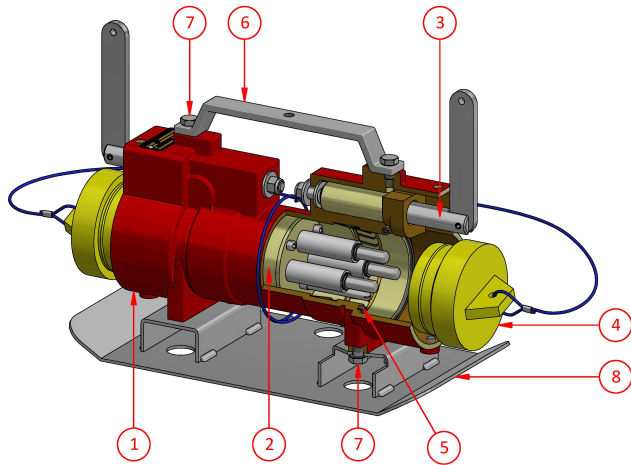

Weight 18kg (no skid) 20kg (with skid)
Dimensions L 450mm W 230mm H 300mm
Compliance Explosion protected to AS/NZS1299 & IEC60079 Series
Materials Manganese Bronze / Brass / PTFE
IP Rating IP66/68

Ordering Procedure

- 1 Select complete Back to Back from Table 1

Table 1



Part Number	Description	Colour
AH334B	3300V Back to Back Receptacle	Red
AH334BS	3300V Back to Back Receptacle c/w skid	Red

Spare Parts

#	Part Number	Description
1	F-4033-334	3300V Back to Back Body c/w items 1, 3, 5, 6 & 7
2	F-4585-3	Interior c/w screws AH115112 M6 x 16 sct. head
3	F-329	Jacking Screw
4	F-311	Sealing Plug
5	4401-3	Seal
6	4035	Lifting Handle
7	AH113111	Screw M10 x 16 hex. head
8	4043S	Skid Plate

CMI Head Office NSW | (02) 9807 6155 | F3, 3-29 Birnie Ave, Lidcombe, NSW, 2141 | nswsales@cmielectrical.com.au
CMI QLD-Brisbane
 (07) 3863 0749
 485A Zillmere Road,
 Zillmere QLD 4034
 southqdsales@cmielectrical.com.au

CMI QLD - Rockhampton
 (07) 4921 0978
 Shop 3 at 76 Hollingsworth Street,
 North Rockhampton Qld 4701
 northqdsales@cmielectrical.com.au

CMI VIC
 (03) 9532 1233
 3 Dissik Street,
 Cheltenham VIC 3192
 vicsales@cmielectrical.com.au

CMI WA
 (08) 9358 1788
 36 Division Street,
 Welshpool WA 6106
 wasales@cmielectrical.com.au