



Back to Back Receptacle
AH364B - AH314B

300 Amp Series

660V - 1100V

AH364BS - AH314BS

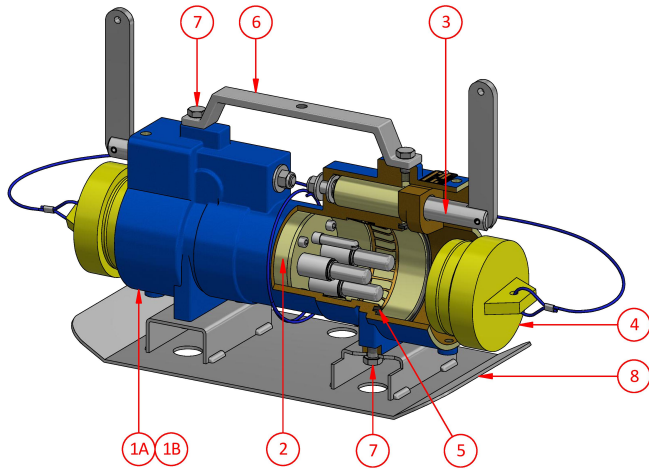

Weight 18kg (no skid) 20kg (with skid)
Dimensions L 450mm W 230mm H 300mm
Compliance Explosion protected to AS/NZS1299 & IEC60079 Series
Materials Manganese Bronze / Brass / PTFE
IP Rating IP66/68

Ordering Procedure

1

Select complete Back to Back from Table 1

Table 1

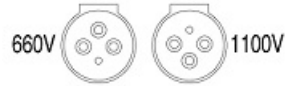

Part Number	Description	Colour
AH364B	660V Back to Back Receptacle	Orange
AH314B	1100V Back to Back Receptacle	Blue
AH364BS	660V Back to Back Receptacle c/w skid	Orange
AH314BS	1100V Back to Back Receptacle c/w skid	Blue

Spare Parts

#	Part Number	Description
1A	F-4033-364	660V Back to Back Body c/w items 1A, 3, 5, 6 & 7
1B	F-4033-314	1100V Back to Back Body c/w items 1B, 3, 5, 6 & 7
2	F-4585-1	Interior c/w screws AH115112 M6 x 16 skt. head
3	F-329	Jacking Screw
4	F-311	Sealing Plug
5	4401-3	Seal
6	4035	Lifting Handle
7	AH113111	Screw M10 x 16 hex. head
8	4043S	Skid Plate

CMI Head Office NSW | (02) 9807 6155 | F3, 3-29 Birnie Ave, Lidcombe, NSW, 2141 | nswsales@cmielectrical.com.au
CMI QLD-Brisbane
(07) 3863 0749
485A Zillmere Road,
Zillmere QLD 4034
southqldsales@cmielectrical.com.au

CMI QLD - Rockhampton
(07) 4921 0978
Shop 3 at 76 Hollingsworth Street,
North Rockhampton Qld 4701
northqldsales@cmielectrical.com.au

CMI VIC
(03) 9532 1233
3 Dissik Street,
Cheltenham VIC 3192
vicsales@cmielectrical.com.au

CMI WA
(08) 9358 1788
36 Division Street,
Welshpool WA 6106
wasales@cmielectrical.com.au