

Back to Back Receptacle
AH164B - AH114B
AH164BS - AH114BS

150 Amp Series
660V - 1100V

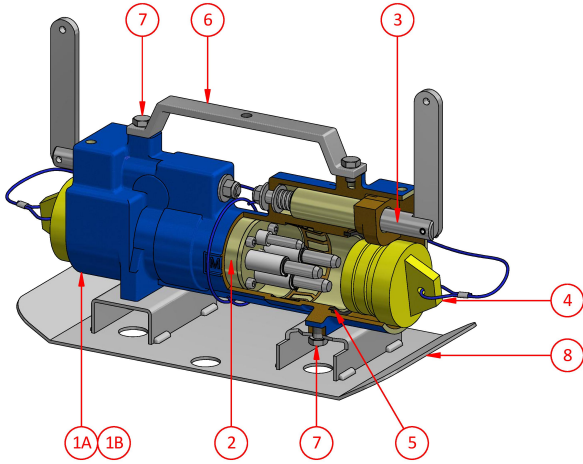

Weight 14kg (no skid) 17kg (with skid)
Dimensions L 450mm W 230mm H 300mm
Compliance Explosion protected to AS/NZS1299 & IEC60079 Series
Materials Manganese Bronze / Brass / PTFE
IP Rating IP66/68

Ordering Procedure

1

Select complete Back to Back from Table 1

Table 1

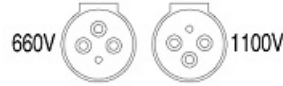

Part Number	Description	Colour
AH164B	660V Back to Back Receptacle	Orange
AH114B	1100V Back to Back Receptacle	Blue
AH164BS	660V Back to Back Receptacle c/w skid	Orange
AH114BS	1100V Back to Back Receptacle c/w skid	Blue

Spare Parts

#	Part Number	Description
1A	F-4117-164	660V Back to Back Body c/w items 1A, 3, 5, 6 & 7
1B	F-4117-114	1100V Back to Back Body c/w items 1B, 3, 5, 6 & 7
2	F-348-1	Interior c/w screws AH115135 M6 x 35 skt. head
3	F-329	Jacking Screw
4	F-310	Sealing Plug
5	4401-2	Seal
6	4035	Lifting Handle
7	AH113111	Screw M10 x 16 hex. head
8	4043S	Skid Plate

CMI Head Office NSW | (02) 9807 6155 | F3, 3-29 Birnie Ave, Lidcombe, NSW, 2141 | nswsales@cmielectrical.com.au
CMI QLD-Brisbane | (07) 3863 0749 | 485A Zillmere Road, Zillmere QLD 4034 | southqldsales@cmielectrical.com.au
CMI QLD - Rockhampton | (07) 4921 0978 | Shop 3 at 76 Hollingsworth Street, North Rockhampton Qld 4701 | northqldsales@cmielectrical.com.au

CMI VIC | (03) 9532 1233 | 3 Dissik Street, Cheltenham VIC 3192 | vic-sales@cmielectrical.com.au

CMI WA | (08) 9358 1788 | 36 Division Street, Welshpool WA 6106 | wasa-sales@cmielectrical.com.au